

CEN-01 PROGRAMMABLE CTCSS ENCODER

OVERVIEW

The CEN-01 is a miniature crystal controlled CTCSS Encoder preset to one of 47 discreet tone frequencies. Tone selection is programmable through the use of solder pad jumpers. Tone generation is crystal controlled so tone measurement equipment is not required for alignment. A transmit high pass filter is included to reduce the possibility of false decoding. The H option includes a second header to allow remote tone frequency programming. The S option adds dip switch tone frequency programming.

SPECIFICATIONS

Frequency Range	67.0 to 254.1Hz selectable in 47 discreet tones
Frequency Stability	±0.1% nominal
Encode output level	Adjustable to 700mV (no load)
Encode Distortion	1.5% typical
High Pass Filter (Transmit)	Attenuates frequencies below 300 Hz in the transmit audio path to reduce false CTCSS decoding.
Input Controls	Push To Talk (normal or inverted polarity selectable) Monitor (normal or inverted polarity selectable)
Operating Voltage	+5.5 to +28 volts
Operating Current	5 mA nominal
Operating Temperature	-20 to +70 °C
Size	14.6 x 23.5 x 4.5mm (0.575" x 0.925" x 0.175") With H (header) / S (switch) option 14.6 x 23.5 x 7.0mm (0.575" x 0.925" x 0.276")
Interfacing	11 pin miniature header (mating connector with 30cm (12") color coded flying leads provided) Second 11 pin miniature header provided with H option for control of tone frequencies.
Mounting	Double Sided Tape (Supplied)

SPECIFICATIONS SUBJECT TO CHANGE WITHOUT NOTICE

INTERFACING

Interfacing to the CEN-01 is performed with a color coded flying lead wire harness. To mount the CEN-01, remove the protective covering from the supplied double sided tape and apply to bottom side of printed circuit board. Next remove the remaining protective covering from the double sided tape and attach to the desired location. Mounting surface must be dry and free of dirt, dust and grease. Assure correct tone selection and options are selected before double sided tape is applied to the P.C. Board. To reduce the potential for interference to the board, it is suggested the board is mounted away from areas of high R.F. levels. Also, it is recommended to keep the interface leads as short as possible to reduce R.F. pickup. Remote tone frequency programming is available with the H option. Tone selection is accomplished by connecting the appropriate wires of harness P2 to ground (negative supply). See Table 3 for wire selection.

Color	PIN #	Function	Description
RED	1	Positive Power Supply	Connect to a positive +5.5 to +28V supply.
BLACK	5	Negative Power Supply	Connect to supply ground.
YELLOW	6	(CTCSS) Tone Out	Connect to transmitter CTCSS input or to a point after all pre-emphasis and limiting circuitry. Adjust R4 for proper level.
GRAY	3	PTT	Connect to Push to Talk circuitry. Factory configured for a "Low" level to activate Encoder. For "High" level to activate the encoder remove solder bridge jumper from JU-7 A-C and add a solder bridge jumper to JU-7 B-C.
VIOLET	9	Transmit Audio Input	Connect this input to the transmitted audio.
ORANGE	8	Transmit Audio Output	This output is the transmitted speech audio with frequencies below 255 Hz reduced by 30 dB. Use of the filtered transmitted audio reduces the chance of false decode at the receiver.

Table 1

Jumper	Designator	Function
JU-1 to JU-6		See Table 3 for proper CTCSS tone selection.
JU-7	PTT	A-C Bridged* = Tone Out is activated with a ground to PTT Input. B-C Bridged = Tone Out is activated with PTT input high (not grounded).

* Signifies factory default configuration.

Note 1: Only one jumper is bridged per jumper (JU). i.e. A-C or B-C, not both.

Table 2

SCHEMATIC

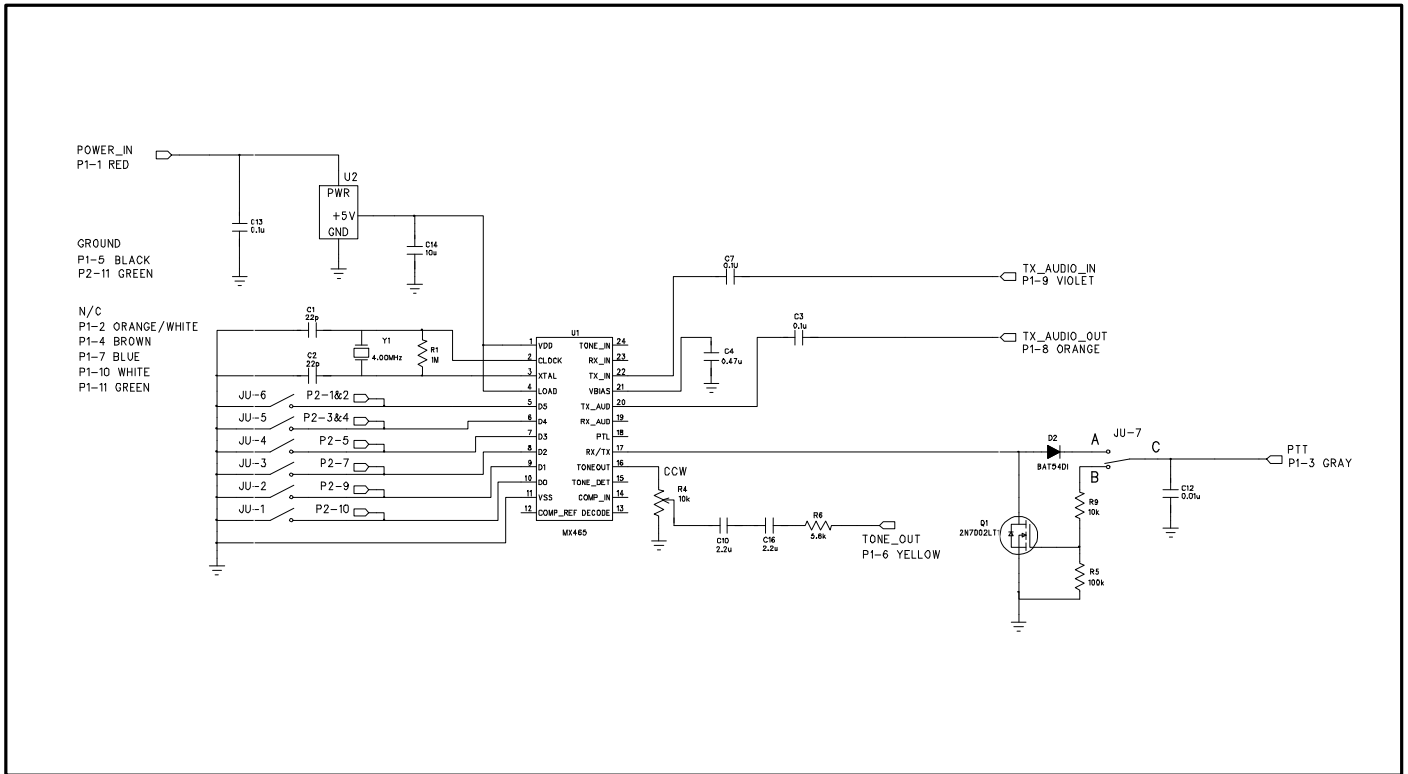

Figure 1

PCB-TOP SIDE

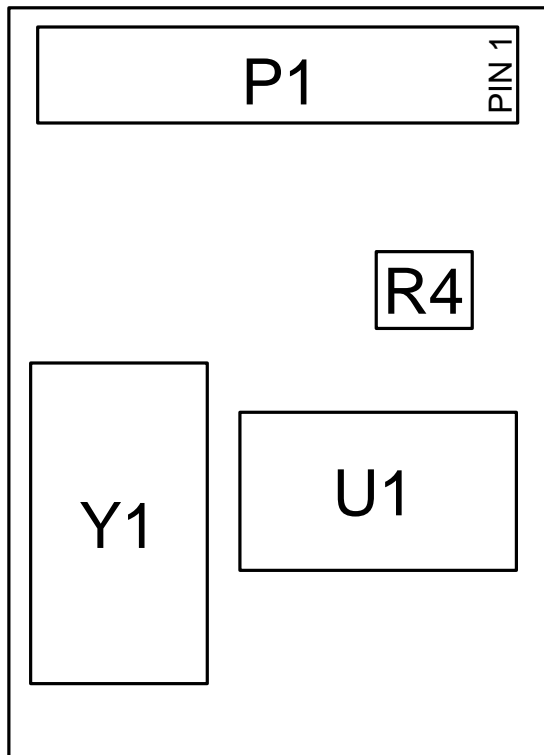

Figure 2

PCB-BOTTOM

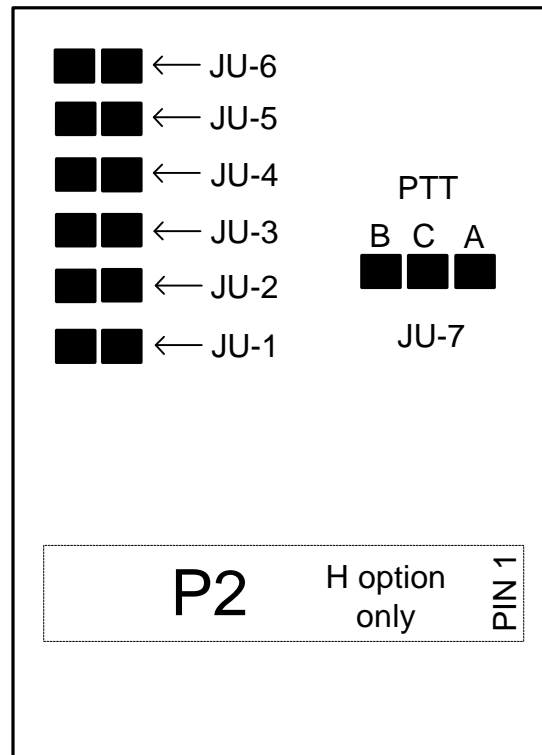

Figure 3

CODE	FREQ. (Hz)	TONE PROGRAMMING JUMPERS					
H Header Option*		P2-10	P2-9	P2-7	P2-5	P2-4	P2-2
S Switch option		SW-1	SW-2	SW-3	SW-4	SW-5	SW6
Jumper		JU-1	JU-2	JU-3	JU-4	JU-5	JU-6
XZ	67.0	open	open	open	open	open	open
WZ	69.3	open	bridge	bridge	open	open	open
XA	71.9	open	open	open	open	open	bridge
WA	74.4	bridge	open	open	open	open	open
XB	77.0	open	open	open	open	bridge	bridge
WB	79.7	open	bridge	open	open	open	open
YZ	82.5	bridge	open	open	open	open	bridge
YA	85.4	bridge	bridge	open	open	open	open
YB	88.5	bridge	open	open	open	bridge	bridge
ZZ	91.5	open	open	bridge	open	open	open
ZA	94.8	open	bridge	open	open	open	bridge
ZB	97.4	bridge	open	bridge	open	open	open
1Z	100.0	open	bridge	open	open	bridge	bridge
1A	103.5	bridge	bridge	open	open	open	bridge
1B	107.2	bridge	bridge	open	open	bridge	bridge
2X	110.9	open	open	bridge	open	open	bridge
2A	114.8	open	open	bridge	open	bridge	bridge
2B	118.8	bridge	open	bridge	open	open	bridge
3Z	123.0	bridge	open	bridge	open	bridge	bridge
3A	127.3	open	bridge	bridge	open	open	bridge
3B	131.8	open	bridge	bridge	open	bridge	bridge
4Z	136.5	bridge	bridge	bridge	open	open	bridge
4A	141.3	bridge	bridge	bridge	open	bridge	bridge
4B	146.2	open	open	open	bridge	open	bridge
5Z	151.4	open	open	open	bridge	bridge	bridge
5A	156.7	bridge	open	open	bridge	open	bridge
	159.8	open	bridge	bridge	bridge	open	open
5B	162.2	bridge	open	open	bridge	bridge	bridge
6Z	167.9	open	bridge	open	bridge	open	bridge
6A	173.8	open	bridge	open	bridge	bridge	bridge
6B	179.9	bridge	bridge	open	bridge	open	bridge
	183.5	bridge	open	bridge	bridge	open	open
7Z	186.2	bridge	bridge	open	bridge	bridge	bridge
	189.9	open	open	bridge	bridge	open	open
7A	192.8	open	open	bridge	bridge	open	bridge
	196.6	bridge	bridge	open	bridge	open	open
	199.5	open	bridge	open	bridge	open	open
M1	203.5	open	open	bridge	bridge	bridge	bridge
8Z	206.5	bridge	open	open	bridge	open	open
M2	210.7	bridge	open	bridge	bridge	open	bridge
M3	218.1	bridge	open	bridge	bridge	bridge	bridge
M4	225.7	open	bridge	bridge	bridge	open	bridge
9Z	229.1	open	open	open	bridge	open	open
M5	233.6	open	bridge	bridge	bridge	bridge	bridge
M6	241.8	bridge	bridge	bridge	bridge	open	bridge
M7	250.3	bridge	bridge	bridge	bridge	bridge	bridge
OZ	254.1	bridge	bridge	bridge	open	open	open
	NO TONE	bridge	bridge	bridge	bridge	open	open

* H Option Ground available on J2-11 (GREEN)

Table 3